

# Maxeon 3

SPR-MAX3-XXX-BLK-R

## Home Solar Panel

400–415 W | Up to 21.9% Efficient



Ideal for residential applications



Black backsheet, black frame

### More Lifetime Energy

Designed to maximise energy generation through leading efficiency, enhanced performance in high temperatures, and higher energy conversion in low-light conditions like mornings, evenings and cloudy days.

### Uncompromising Durability

Engineered to power through all types of weather conditions with crack-resistant cells and reinforced connections that protect against fatigue and corrosion, to an electrical architecture that mitigates the impact of shade and prevents hot-spot formation.



### Superior Sustainability

Clean ingredients, responsible manufacturing, and lasting energy production for 40 years make Maxeon panels the most sustainable choice in solar.



### The Industry's Longest Warranty

Maxeon panels are covered by a 40-year warranty<sup>1</sup> backed by extensive third-party testing and field data from more than 50 million panels deployed worldwide.

	Installed by a Maxeon Partner	Standard
Product coverage (years)	40	25
Performance coverage (years)	40	25
Service coverage (years)	40	N/A
Minimum warranted output in Year 1		98.0%
Maximum annual degradation		0.25%



# Maxon 3 POWER: 400–415 W | EFFICIENCY: Up to 21.9%

Electrical Data				
	SPR-MAX3-415-BLK-R	SPR-MAX3-410-BLK-R	SPR-MAX3-405-BLK-R	SPR-MAX3-400-BLK-R
Nominal Power (P <sub>nom</sub> ) <sup>2</sup>	415 W	410 W	405 W	400W
Power Tolerance	+5/0%	+5/0%	+5/0%	+5/0%
Panel Efficiency	21.9%	21.6%	21.4%	21.1%
Rated Voltage (V <sub>mpp</sub> )	35.3 V	35.1 V	34.9V	34.7V
Rated Current (I <sub>mpp</sub> )	11.75 A	11.68 A	11.61 A	11.54 A
Open-Circuit Voltage (V <sub>oc</sub> ) (+/-3%)	40.7 V	40.7 V	40.7 V	40.6V
Short-Circuit Current (I <sub>sc</sub> ) (+/-3%)	12.64 A	12.63 A	12.62 A	12.60 A
Max. System Voltage	1000 V UL			
Maximum Series Fuse	25 A			
Power Temp Coef.	-0.27% / °C			
Voltage Temp Coef.	-0.236% / °C			
Current Temp Coef.	0.058% / °C			

Tests And Certifications	
Standard Tests <sup>3</sup>	UL 61730 (Type 2 Fire Rating)
Ammonia Test	IEC 62716
Desert Test	IEC 60068-2-68, MIL-STD-810G
Salt Spray Test	IEC 61701 (maximum severity)
PID Test	1000 V: IEC 62804
Available Listings	UL, FSEC
IFLI Declare Label	First solar panel labeled for ingredient transparency and LBC-compliance. <sup>4</sup>
Cradle to Cradle Certified™ Silver	First solar panel line certified for material health, water stewardship, material reutilization, renewable energy & carbon management, and social fairness. <sup>5</sup>
Green Building Certification Contribution	Panels can contribute additional points toward LEED and BREEAM certifications.
EHS Compliance	RoHS, Recycle Scheme, REACH SVHC-163

Operating Condition And Mechanical Data	
Temperature	-40°F to +185°F (-40°C to +85°C)
Solar Cells	112 Monocrystalline Maxon Gen 3
Tempered glass	0.13 in (3.2 mm), high-transmission tempered anti-reflective
Junction Box	IP-68, Stäubli (MC4), 2 bypass diodes
Weight	46.7 lbs (21.2 kg)
Max. Load <sup>6</sup>	Wind: 112 psf, 5400 Pa, 550 kg/m <sup>2</sup> back Snow: 112 psf, 5400 Pa, 550 kg/m <sup>2</sup> front HVHZ: <sup>7</sup> 112 psf, 5400 Pa front and back
Impact Resistance	1.77 inch (45 mm) diameter hail at 68.7 mph (30.7 m/s)
Frame	Class 1 black anodized (highest AAMA rating)

Packaging Configuration	
Number of modules per pallet	26
Number of pallets per 40ft HQ container	24
Number of modules per 40ft HQ container	624
Number of pallets per 53ft container	32
Number of pallets per 53ft container	832

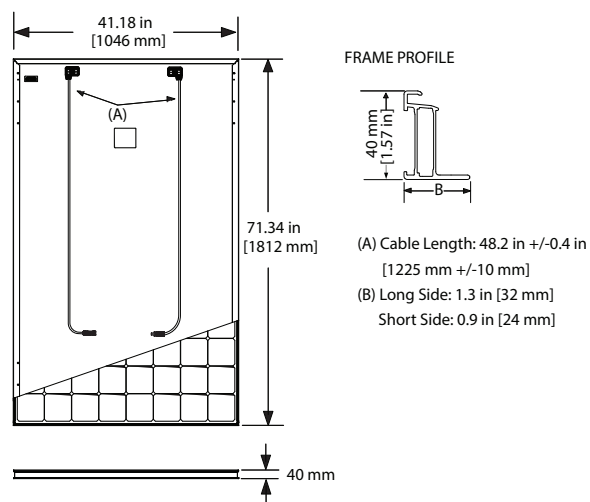

1 40-year warranty terms are not available in all countries or in all installations. In the United States, 40-year warranty terms require digital warranty registration and installation by an authorized Maxon Partner. Please refer to our published warranty documents or contact us for more information.

2 Standard Test Conditions (1000 W/m<sup>2</sup> irradiance, AM 1.5, 25° C). NREL calibration Standard: SOMS current, LACCS FF and Voltage.

3 Type 2 fire rating per UL 61730, Class C fire rating per IEC 61730.

4 Maxon DC panels first received the International Living Future Institute Declare Label in 2016.

5 Maxon DC panels are Cradle to Cradle Certified™ Silver - [www.c2ccertified.org/products/scorecard/maxon\\_solar\\_panels\\_-\\_maxeon\\_corporation](http://www.c2ccertified.org/products/scorecard/maxon_solar_panels_-_maxeon_corporation). Cradle to Cradle Certified™ is a certification mark licensed by the Cradle to Cradle Products Innovation Institute.

6 As per IEC 61215-2016 tested and certified. See Safety and Installation Guideline for details.

7 Florida High Velocity Hurricane Zone (HVHZ) or equivalent US building codes. Please refer to the Safety and Installation guide for additional details.

Made in Philippines (Cells)  
 Assembled in Mexico & US (Module)

Specifications included in this datasheet are subject to change without notice.

©2025 Maxon Solar Technologies. All Rights Reserved.

View warranty, patent and trademark information at [maxeon.com/legal](http://maxeon.com/legal).



Please read the safety and installation instructions. Visit [www.maxeon.com/PVInstallGuide](http://www.maxeon.com/PVInstallGuide). Paper version can be requested through [techsupport.na@maxeon.com](mailto:techsupport.na@maxeon.com)

# maxeon